

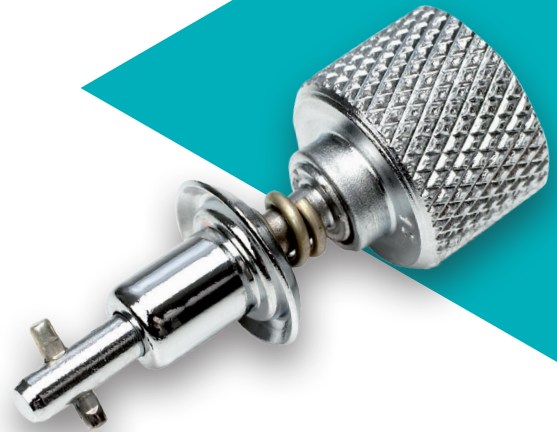

**HOWMET
AEROSPACE**



Camloc 
Traditionally Innovative

Quick Release Fasteners



Latches



Specials

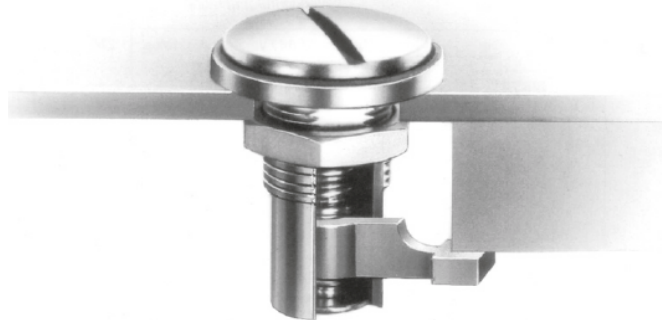

Inserts





	Page
General Information	A-2
Important Information	A-3
Overview on latches	A-4

Tension Latches

V934L Series	B-1 - B-2
V95L Series	C-1 - C-2
V96L Series	D-1 - D-2
1429L Series	E-1 - E-5
V951L Series	F-1 - F-8
V917L & 1449L Series	G-1 - G-5
V18L Series	H-1 - H-4
V46L Series	I-1 - I-2

Index



electrical cabinets



laboratory equipment



machine construction



agriculture



construction



solar



truck



electronic equipment



lighting interior



mould making



automotive/ racing



rail



trailer



wind

The Camloc brand was established in 1937. Since that time our fastening systems have been successfully integrated into numerous applications within many different industries.

Our customers benefit from our more than 80 years of fastening experience.

We provide local support for innovative, high quality fastening systems supplied globally to the strictest environmental and working conditions.



IATF 16949:2016



ISO 14001:2015

Your Howmet Fastening Systems team

Disclaimer:

Parts listed are subject to technical changes. All dimensions in mm. All information is correct to the best of our knowledge at the time of printing. No liability for disadvantages caused by printing errors or false application.

How It Operates

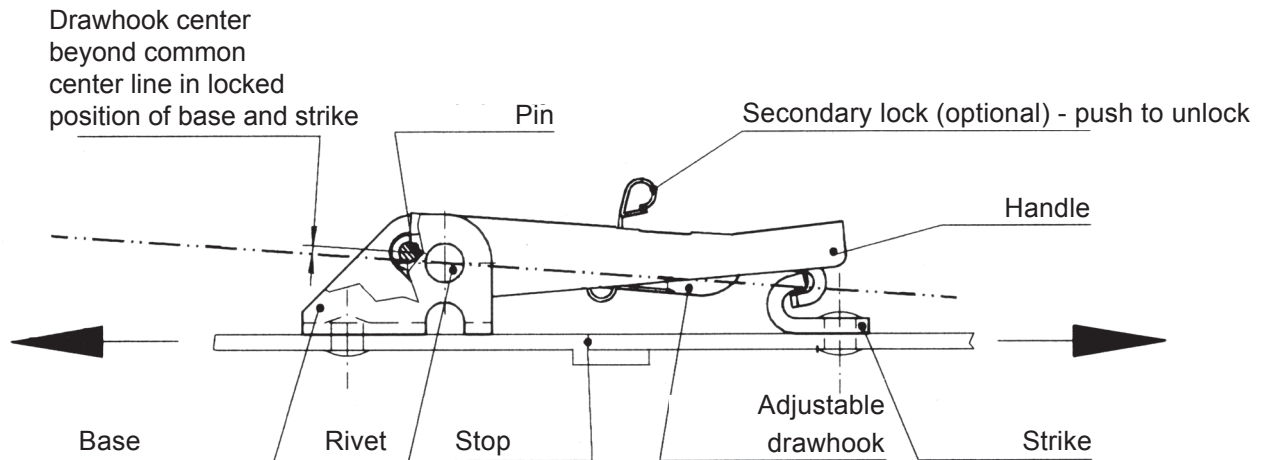

- Tension latches provide a quick release yet secure locking mechanism. They can take high tensile loads. Shear forces must be kept off the tension latch by the assembly design.
- Through lever action, the panels connected with the tension latch and the strike are pulled together. If necessary, a stop must be provided.
- Positive lock is achieved when drawhook center is beyond the common center line of the base and strike.

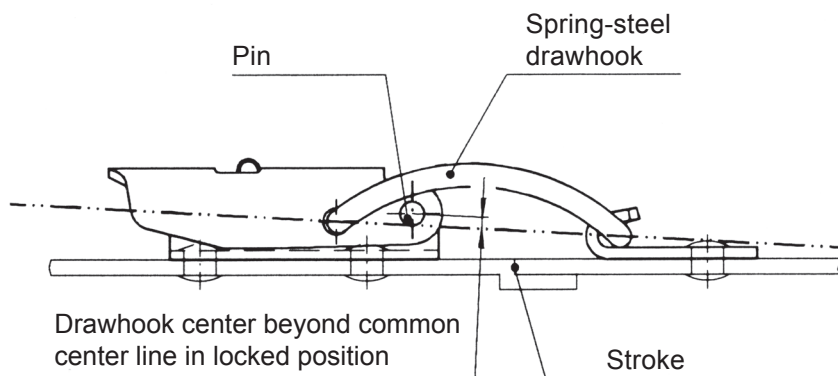

- For unlocking, the secondary lock, if fitted, is operated and the handle lifted. For locking, the secondary lock automatically engages.
- Most of the tension latches can be adjusted by a threaded drawhook. For non-threaded drawhook series the spring steel or wire drawhook gives tolerance compensation and joint tension.

Click here: [Camloc Draw Latch](#) (Youtubelink)





Overview Latches

Series	Max. tensile strength	Working load	without secondary lock	with secondary lock	with hasp	to rivet on or to screw on	to weld on	adjustable drawhook	carbon steel with surface treatment	Stainless steel	Pages
V934L	550 N	310 N	X	X		X			X	X	B1-B2
95L	445 N	220 N	X			X			X	X	C1-C2
V96L	1.000 N	650 N	X			X			X		D1-D2
1429L	1.500 N	1.000 N	X	X		X			X	X	E1-E5
V951L	2.300 N	1.550 N	X	X	X	X	X	X	X	X	F1-F6
V917L	3.600 N	2.700 N	X	X	X	X	X	X	X	X	G1-G5
V18L	6.000 N	4.200 N	X	X	X	X	X	X	X	X	H1-H4
V46L	4.400 N	3.000 N	X			X	X	X	X		I1

* Limitations within series possible. Please see (foot) notes at catalogue pages.

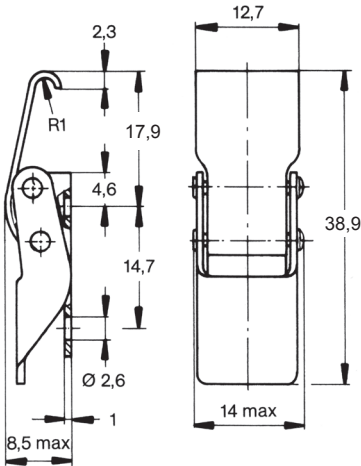
Max. tensile strength 550 N
Working load 310 N

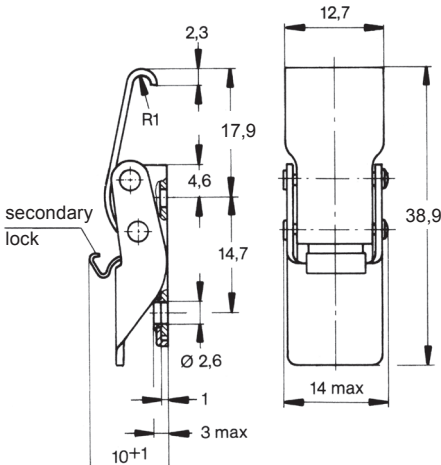
Style	Dimensions	Materials / Finish	Part No.
		Stainless steel Steel / zinc-plated, CrVI-free, clear passivation	V934L01-1-1BP V934L01-1-1AGV
With secondary lock 		Stainless steel Steel / zinc-plated, CrVI-free, clear passivation	V934L01-1X1BP V934L01-1X1AGV

Strikes

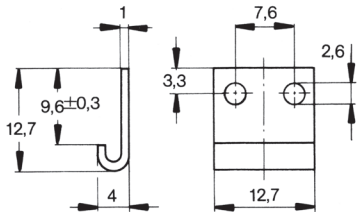
Style	Dimensions	Materials / Finish	D	Part No.
		Stainless steel ¹⁾ Steel / zinc-plated, CrVI-free, clear passivation	2,6	V934L02-1BP V934L02-1AGV

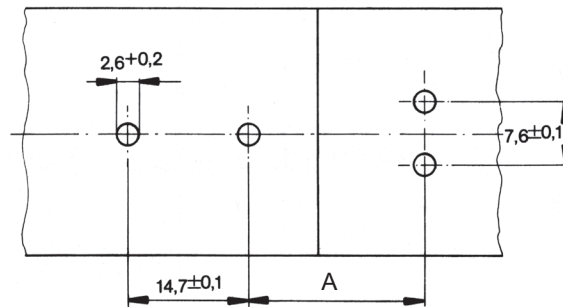
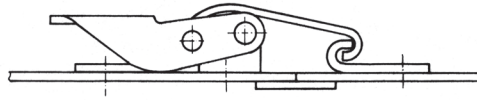

Dimensions



A = min. 23,7 mm, please take into account the application preload and tolerance requirements

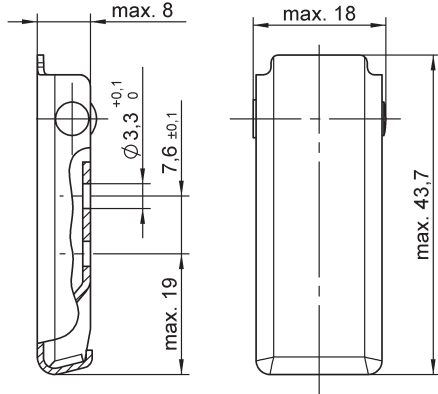

Max. tensile strength 445 N, working load 220 N
 Handle conceals all interior parts and strike
 Self-compensating spring steel drawhook
 Low profile

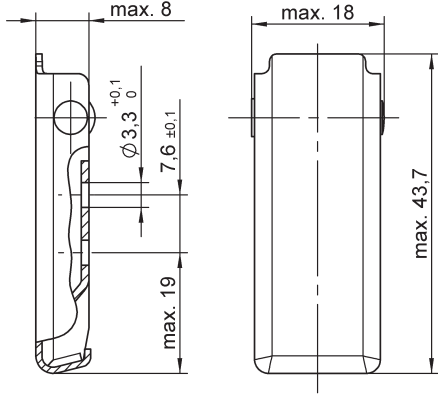
Style	Dimensions	Materials / Finish	Part No.
<p>Self-compensating spring steel drawhook</p> 		Stainless steel	V95L07-1-1BC
<p>Self-compensating spring steel drawhook</p> 		Steel / chrome-plated Interior parts: Steel / zinc-plated, CrVI-free, clear passivation	V95L15-1BD

Strike

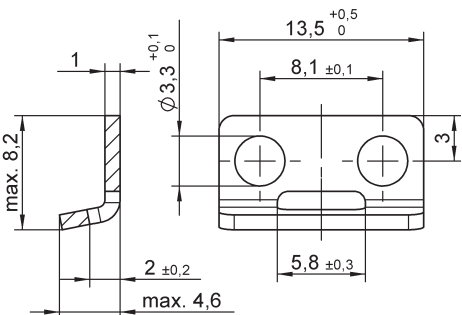
Style	Dimensions	Materials / Finish	Part No.
		Stainless steel	V95H07-1-1BP

Dimensions

Spring steel drawhook tension latch / strike

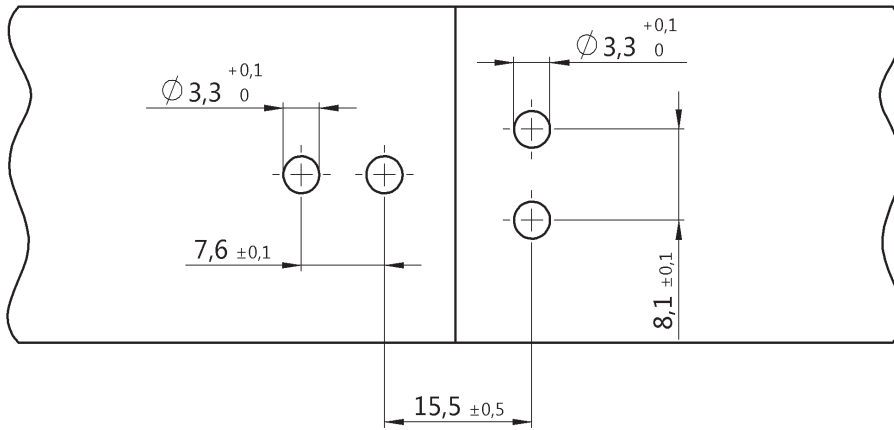
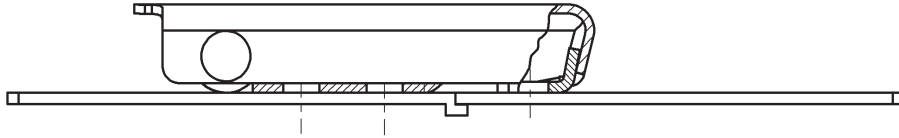

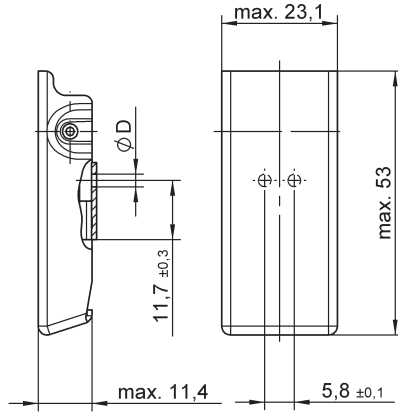

Max. tensile strength 1.000 N, working load 650 N.
Handle conceals all interior parts and strike
Self-compensating spring steel drawhook
Low profile

Style	Dimensions	Materials / Finish	D	Part No.
Self-compensating spring steel drawhook 		Steel / zinc-plated, CrVI-free, clear passivation	2,5	V96L01-1-1A0
			3,2	V96L01-1-2A0
		Steel / chrome-plated Interior parts: Steel / zinc-plated, CrVI-free, clear passivation	2,5	V96L01-1-1AG
			3,2	V96L01-1-2AG

Strike

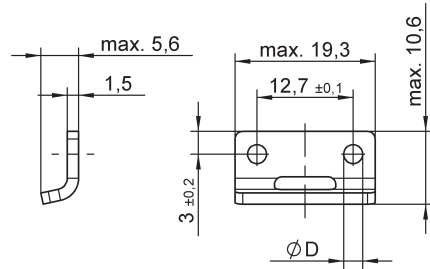

Style	Dimensions	Materials / Finish	D	Part No.
		Steel / zinc-plated, CrVI-free, clear passivation	2,5	V96H01-1-1A0
			3,2	V96H01-1-2A0

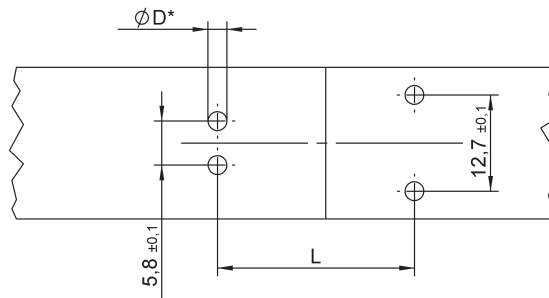
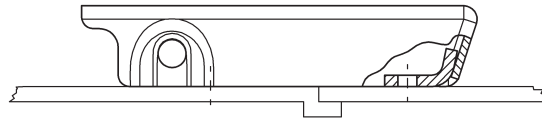
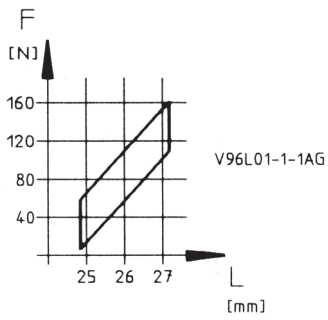
Dimensions



* Ø D see selected version.

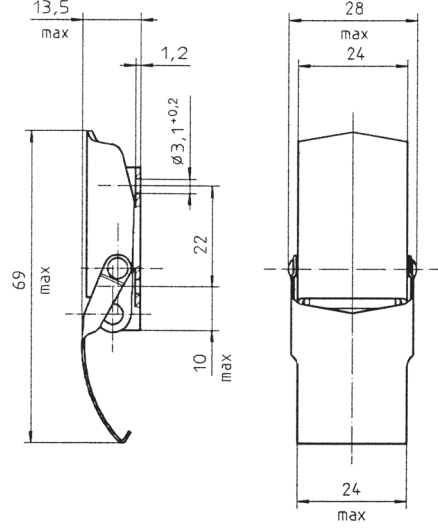

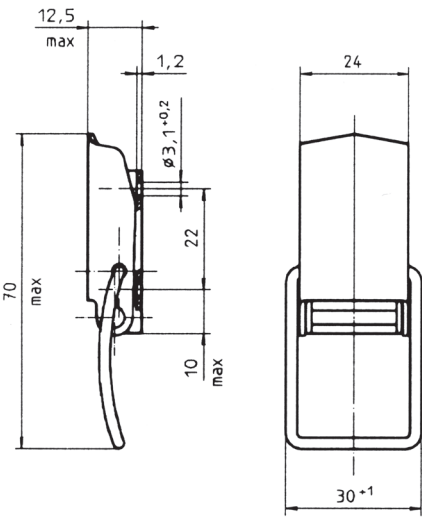
Max. tensile strength 1.500 N, working load up to 1.000 N, see footnotes.
Available with secondary lock
Three different drawhook types available

Style	Dimensions	Materials / Finish	D	Part No.
Spring steel drawhook 		Steel / zinc-plated, CrVI-free, clear passivation ¹⁾	3,1	1429L02-1-1AG
		Stainless steel ²⁾	3,1	1429L02-1-1BP
Wire drawhook 		Steel / zinc-plated, CrVI-free, clear passivation ¹⁾	3,1	1429L02-2-1AG
		Stainless steel ³⁾	3,1	1429L02-2-1BP

¹⁾ Max. tensile strength: 450 N with 1429L8-1AG strike, working load 330 N.

²⁾ Max. tensile strength: 300 N with 1429L8-1BP strike, working load 210 N.

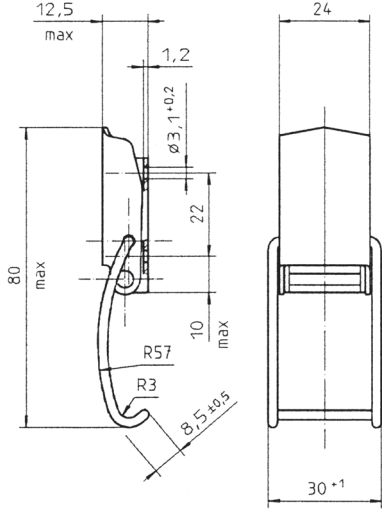

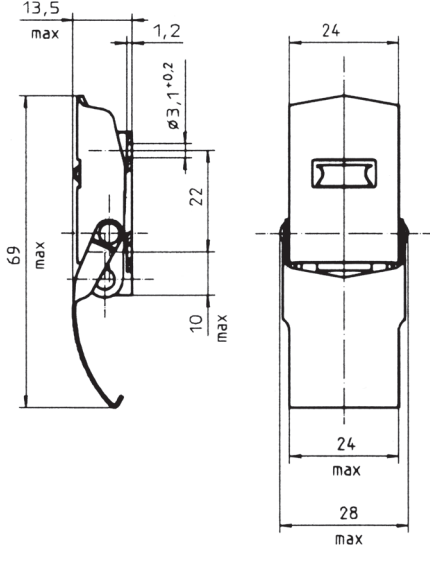
³⁾ Max. tensile strength: 1.500 N with 1429L9-1AG / -1BP strike, working load 1.000 N.

Style	Dimensions	Materials / Finish	D	Part No.
Hooked wire drawhook 		Steel / zinc-plated, CrVI-free, clear passivation ¹⁾	3,1	1429L02-3-1AG
		Stainless steel ¹⁾	3,1	1429L02-3-1BP
Spring steel drawhook and secondary lock 		Steel / zinc-plated, CrVI-free, clear passivation ²⁾	3,1	1429L02-1X1AG
		Stainless steel ³⁾	3,1	1429L02-1X1BP

¹⁾ Max. tensile strength: 1.100 N with 1429L9-1AG / -1BP strike, working load 800 N.
or in conjunction with mating component profile.

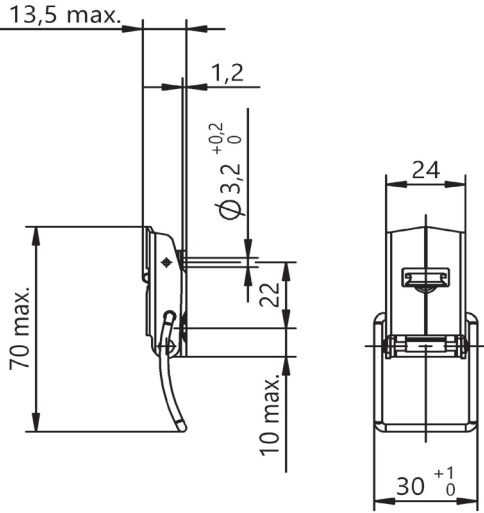

²⁾ Max. tensile strength: 450 N with 1429L8-1AG strike, working load 330 N.

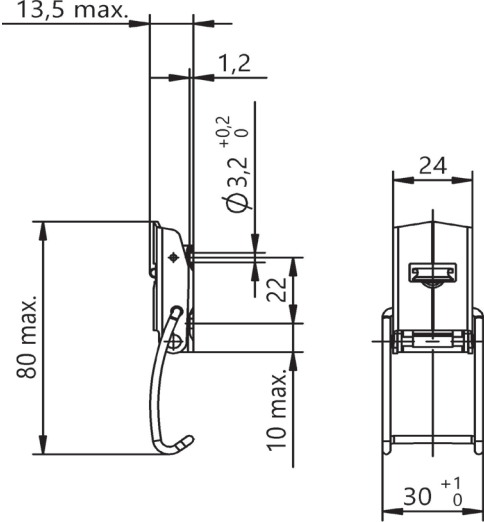
³⁾ Max. tensile strength: 300 N with 1429L8-1BP strike, working load 210 N.

Style	Dimensions	Materials / Finish	D	Part No.
Wire drawhook and secondary lock 		Steel / zinc-plated, CrVI-free, clear passivation ¹⁾	3,1	1429L02-2X1AG
		Stainless steel ¹⁾	3,1	1429L02-2X1BP
Hooked wire drawhook and secondary lock 		Steel / zinc-plated, CrVI-free, clear passivation ²⁾	3,1	1429L02-3X1AG
		Stainless steel ²⁾	3,1	1429L02-3X1BP

¹⁾ Max. tensile strength: max. 1.500 N with 1429L9-1AG / -1BP strike, working load 1.000 N.

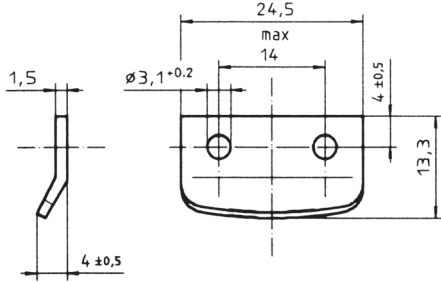
²⁾ Max. tensile strength: max. 1.100 N with 1429L9-1AG / -BP strike, working load 800 N.
or in conjunction with mating component profile.

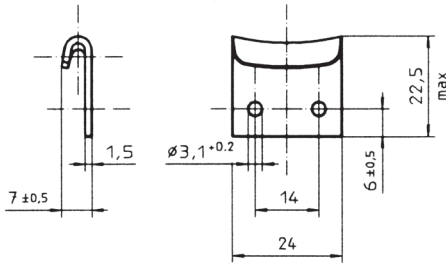
Style	Dimensions	Materials / Finish	D	Part No.
<p>For use with spring steel drawhook</p> 		<p>Steel / zinc-plated, CrVI-free, clear passivation</p> <p>Stainless steel</p>	<p>3,1</p> <p>3,1</p>	<p>1429L8-1AG</p> <p>1429L8-1BP</p>
<p>For use with wire drawhook</p> 		<p>Steel / zinc-plated, CrVI-free, clear passivation</p> <p>Stainless steel</p>	<p>3,1</p> <p>3,1</p>	<p>1429L9-1AG</p> <p>1429L9-1BP</p>

Dimensions

Spring steel drawhook tension latch / strike

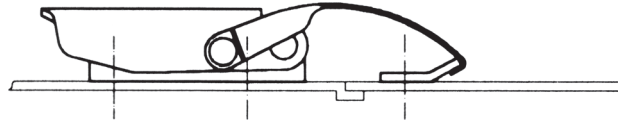

1429L02-1-^{*}
1429L8-^{*}

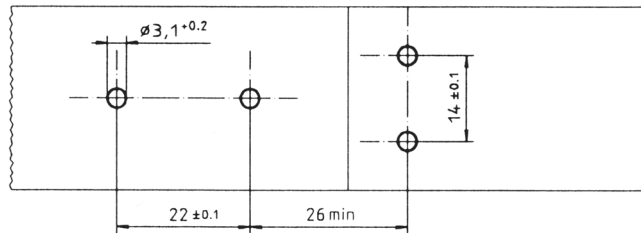

Wire drawhook tension latch / strike

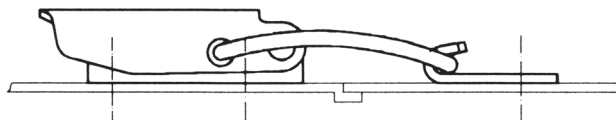

1429L02-2-^{*}
1429L9-^{*}

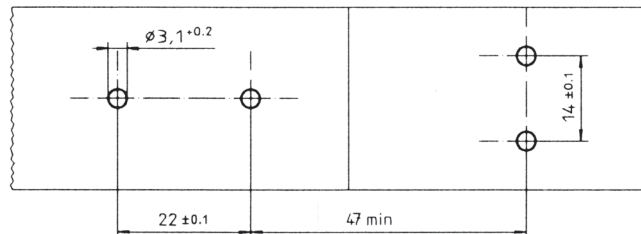

Hooked wire drawhook tension latch / mating component profile

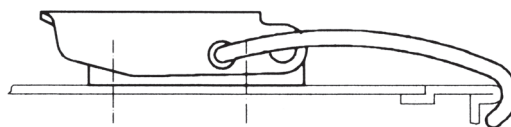

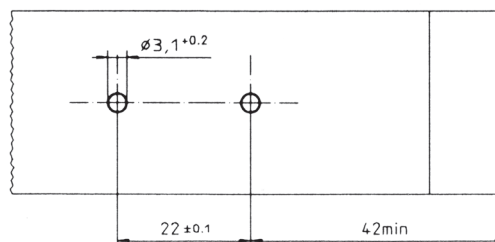

1429L02-3-^{*}
(1429L9-^{*})



Max. tensile strength 2.300 N, working load max 1.550 N, see footnotes.

Adjustable drawhook

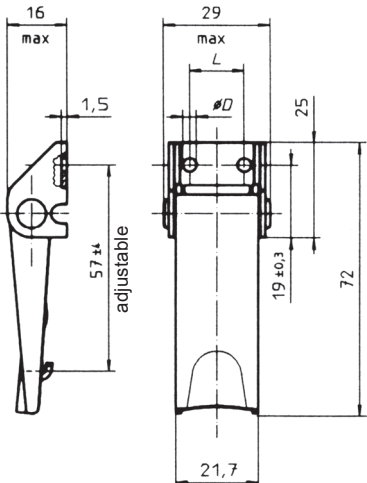
Available with secondary lock and hasp

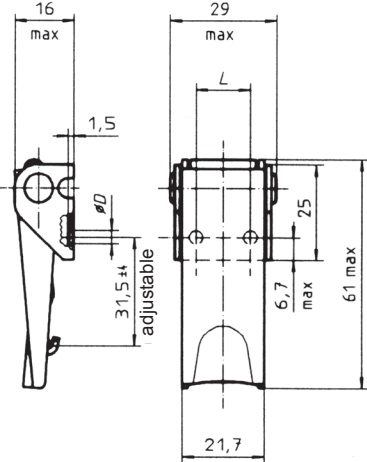
Style	Dimensions	Materials / Finish	Mounting Type ¹⁾	D	L	Part No.
Open base 		Steel / zinc-plated, CrVI-free, clear passivation ²⁾	N	3,6	14,3	V951L02-1-1AGV
		Steel / zinc-plated, CrVI-free, clear passivation ²⁾	N	4,2	12,7	V951L02-1-5AGV
		Steel / zinc-plated, CrVI-free, clear passivation Base: Steel / zinc-plated ²⁾	S	-	-	V951L02-1-2AGV
		Steel / chrome-plated Interior parts: Steel / zinc-plated, CrVI-free, clear passivation ²⁾	N	3,6	14,3	V951L02-1-1AD
		Stainless steel ³⁾	N	3,6	14,3	V951L02-1-1BP
		Stainless steel ³⁾	N	4,2	12,7	V951L02-1-5BP
		Stainless steel ³⁾	S	-	-	V951L02-1-2BP
Concealed base ⁴⁾ 		Steel / zinc-plated, CrVI-free, clear passivation	N	3,6	14,3	V951L03-1-1AGV
		Steel / zinc-plated, CrVI-free, clear passivation	N	4,2	12,7	V951L03-1-5AGV
		Steel / chrome-plated Interior parts: Steel / zinc-plated, CrVI-free, clear passivation	N	3,6	14,3	V951L03-1-1AD
		Stainless steel	N	3,6	14,3	V951L03-1-1BP
		Stainless steel	N	4,2	12,7	V951L03-1-5BP

¹⁾ Mounting type: N = With holes for riveting or screw fixing



S = Without holes, for welding

²⁾ Max. tensile strength: 2.300 N with V951L7-*A* and V951L52-1A* strike, working load 1.550 N.

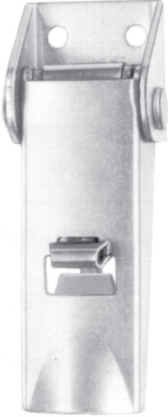
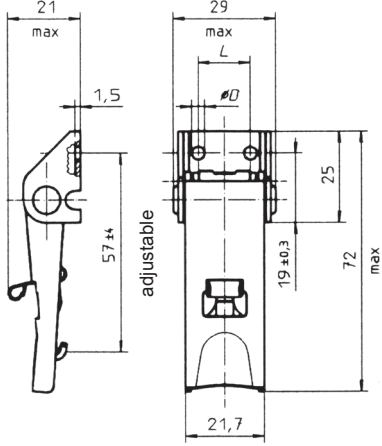

2.000 N with V951L50-1A* strike, working load 1.300 N.

³⁾ Max. tensile strength: 1.500 N with V951L7-*BP and V951L52-1BP strike, working load 1.000 N.

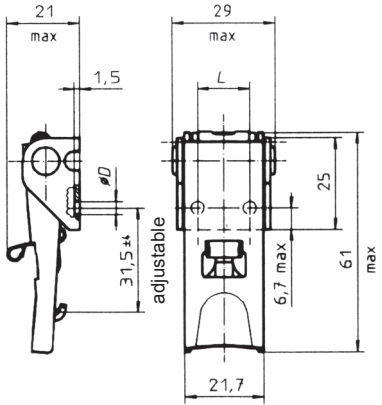

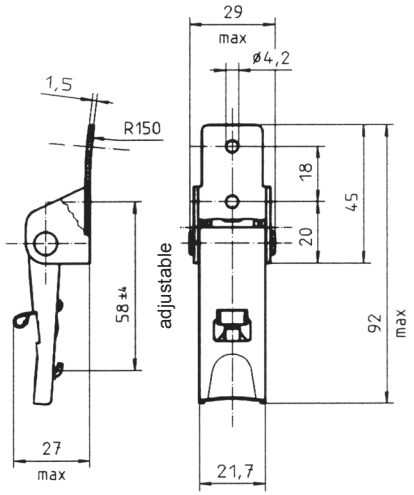

⁴⁾ Due to the mounting geometry, tensile strength reduced to approx. 1200 N, working load 800 N.

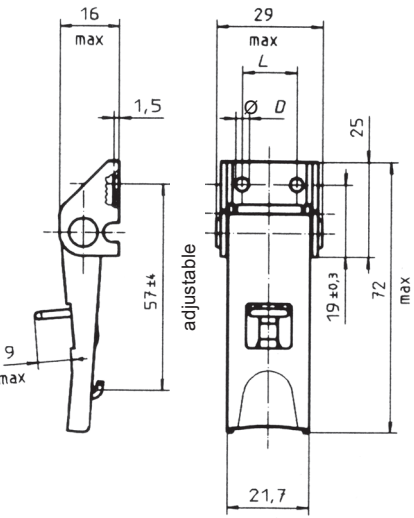
Style	Dimensions	Materials / Finish	Mounting Type ¹⁾	D	L	Part No.
Secondary lock, open base 		Steel / zinc-plated, CrVI-free, clear passivation ²⁾	N	3,6	14,3	V951L04-1X1AGV
		Steel / zinc-plated, CrVI-free, clear passivation ²⁾	N	4,2	12,7	V951L04-1X5AGV
		Steel / chrome-plated Interior parts: Steel / zinc-plated, CrVI-free, clear passivation Secondary lock: Stainless steel	N	3,6	14,3	V951L04-1X1AD
		Stainless steel ³⁾	N	3,6	14,3	V951L04-1X1BP
		Stainless steel ³⁾	N	4,2	12,7	V951L04-1X5BP
		Stainless steel ³⁾	S	-	-	V951L04-1X2BP
Secondary lock, concealed base ⁴⁾ 		Steel / zinc-plated, CrVI-free, clear passivation	N	4,2	12,7	V951L03-1X5AGV
		Steel / chrome-plated Interior parts: Steel / zinc-plated, CrVI-free, clear passivation Secondary lock: Stainless steel	N	3,6	14,3	V951L03-1X1AD
		Stainless steel	N	3,6	14,3	V951L03-1X1BP
		Stainless steel	N	4,2	12,7	V951L03-1X5BP

For footnotes refer to page F-1.

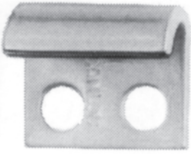
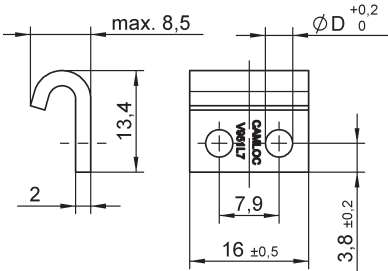
Style	Dimensions	Materials / Finish	Mounting Type ¹⁾	D	Part No.
Secondary lock, high base 		Steel / zinc-plated, CrVI-free, clear passivation Secondary lock: Stainless steel ²⁾	N	4,2	V951L05-1X1AGV
		Stainless steel ³⁾	N	4,2	V951L05-1X1BP
Hasp 	 Hasp for Padlock \varnothing 6 max.	Steel / zinc-plated, CrVI-free, clear passivation ²⁾ Base: Steel / zinc-plated	S	-	V951L01-1Y2AGV
		Steel / zinc-plated, CrVI-free, clear passivation ²⁾	N	4,2	V951L01-1Y5AGV

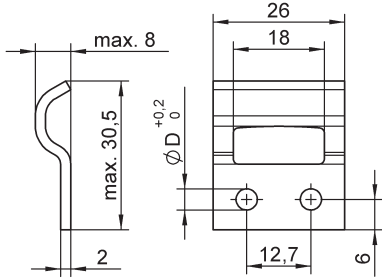
For footnotes refer to page F-1.

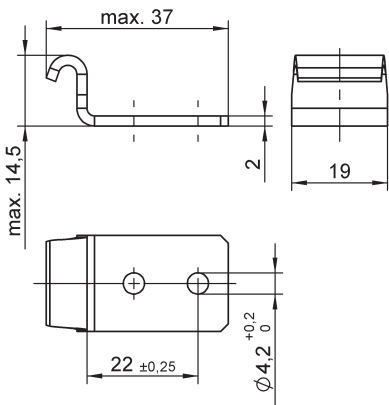
Style	Dimensions	Materials / Finish	Mounting Type ¹⁾	D	Part No.
Open 		Steel / zinc-plated, CrVI-free, clear passivation	N	3,6	V951L7-1AGV
		Steel / zinc-plated, CrVI-free, clear passivation	N	4,2	V951L7-5AGV
		Steel / zinc-plated	S ²⁾	-	V951L7-2AZ
		Steel / chrome-plated	N	3,6	V951L7-1AD
		Stainless steel	N	3,6	V951L7-1BP
		Stainless steel	N	4,2	V951L7-5BP
		Stainless steel	S	-	V951L7-2BP
Closed 		Steel / zinc-plated, CrVI-free, clear passivation	N	4,2	V951L50-1AGV
		Stainless steel	N	4,2	V951L50-1BP
		Stainless steel	N	3,6	V951L50-2BP
		Stainless steel	S	-	V951L50-3BP
Corner mounting 		Steel / zinc-plated, CrVI-free, clear passivation	N	4,2	V951L52-1AGV
		Stainless steel	N	4,2	V951L52-1BP

¹⁾ Mounting type: N = With holes for riveting or screw fixing
S = Without holes, for welding

²⁾ Material C45, HRC 36-39 steel, please use high-alloy filler welding rods

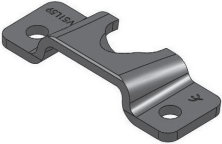
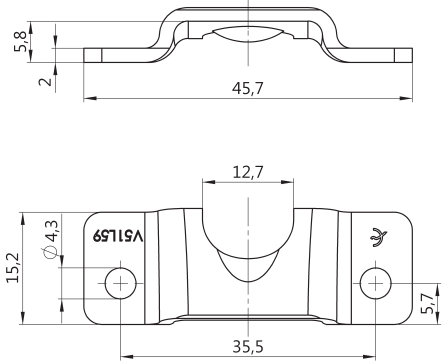
Product	Dimensions	Materials / Finish	Mounting Type	D	Part No.
<p>wide Version</p> 		zinc-nickel plated transparent, CrVI-free passivated and sealed	N	4,3	V51L59-1ASN

- 1) Befestigung: N = mit Bohrungen zum Nieten bzw. Schrauben
S = ohne Bohrungen zum Schweißen
- 2) Werkstoff: Stahl C45, HRC 36-39, bitte hochlegierte Schweißzusatzwerkstoffe verwenden.

Accessories

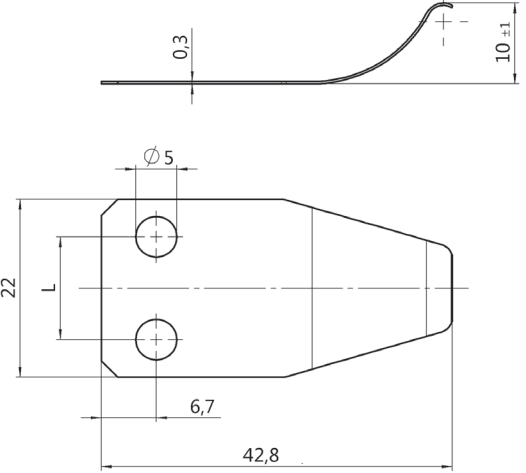
Dimensions	Material / Finish	Hole Distance L	D	Part No.
<p>Lift Spring</p> 	stainless steel / passivated	14,3	5,0	V951L61-4BP
	stainless steel / passivated	12,7	5,0	V951L61-5BP

This lift spring can only be used in combination with latches of V951L series with open base.

Dimensions

Open-base tension latch / open strike

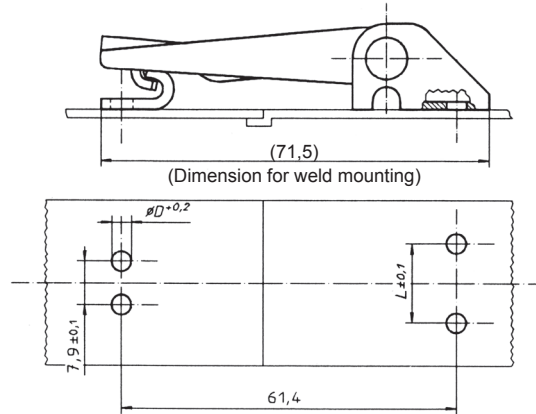

V951L02-
V951L04-
V951L01-*

V951L7-*

Select diameter D and distance L in accordance with the strike and tension latch style.

Concealed-base tension latch / open strike

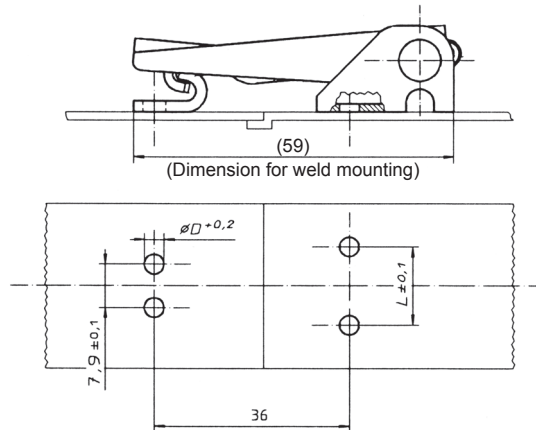

V951L03-*

V951L7-*

Select diameter D and distance L in accordance with the strike and tension latch style.

Open-base tension latch / closed strike

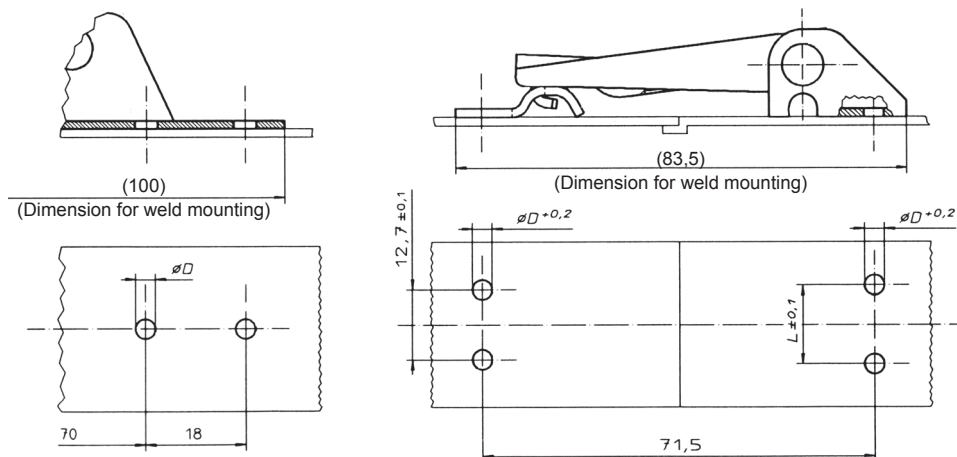

V951L02-
V951L04-
V951L01-*

V951L50-*

V951L05-

Select diameter D and distance L in accordance with the strike and tension latch style.

Dimensions

Concealed-base tension latch / closed strike

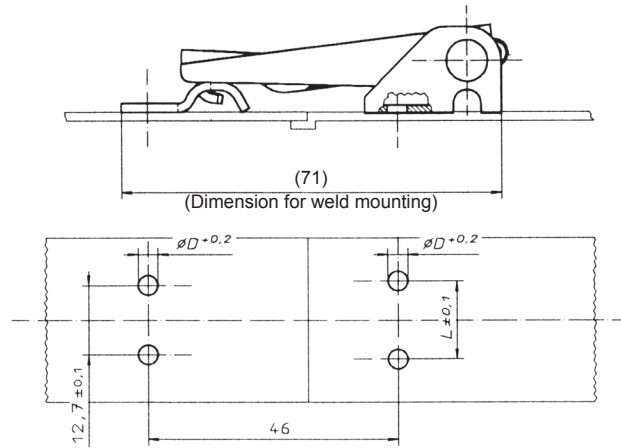

V951L03-*

V951L50-*

Select diameter D and distance L in accordance with the strike and tension latch style.

Open-base tension latch / corner-mounting strike

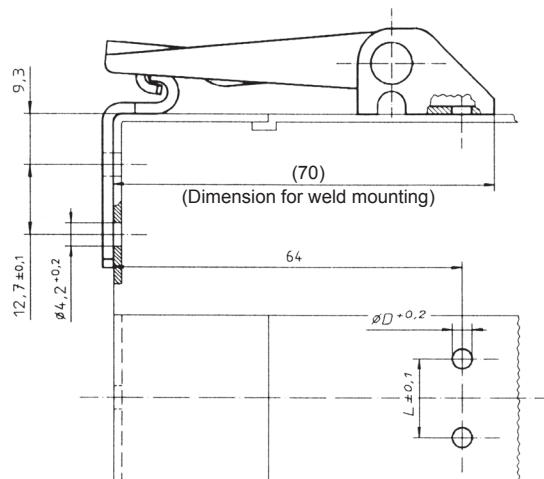

V951L02-*

V951L04-*

V951L01-*

V951L52-*

Select diameter D and distance L in accordance with the strike and tension latch style.

Concealed-base tension latch / corner-mounting strike

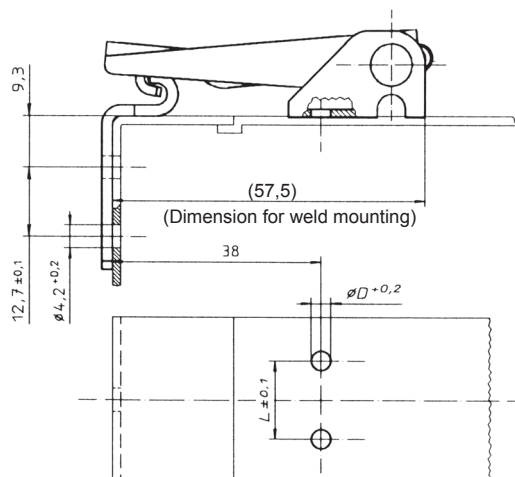

V951L03-*

V951L52-*

Select diameter D and distance L in accordance with the strike and tension latch style.

Dimensions

Open-base tension latch / wide strike

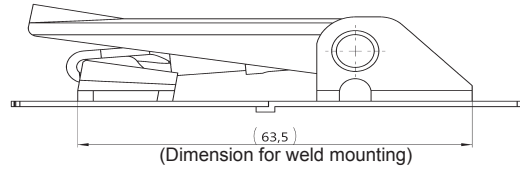

V951L01-*
V951L02-*
V951L04-*

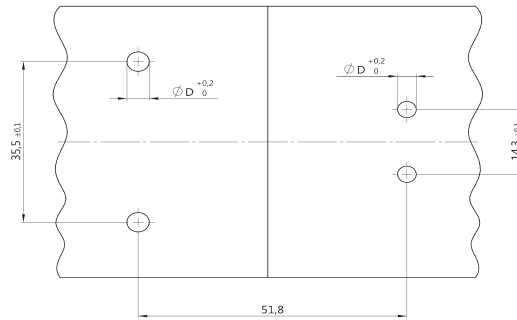

V51L59-*

Select diameter D and distance L in accordance with the strike and tension latch style.

Concealed-base tension latch / wide strike

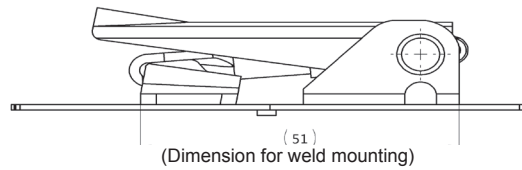

V951L03-*

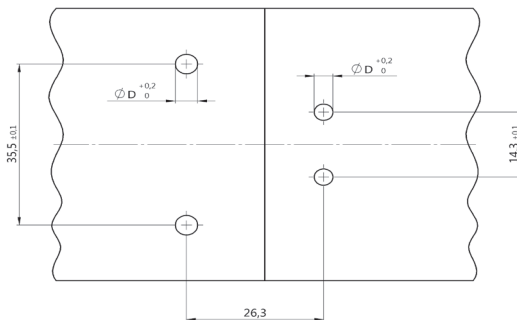



V951L59-*

Select diameter D and distance L in accordance with the strike and tension latch style.

Max. tensile strength 3.600 N, working load max. 2.700 N, see footnotes.

Adjustable drawhook

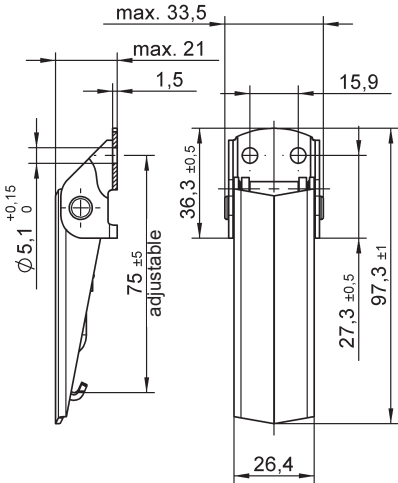
Available with secondary lock and hasp

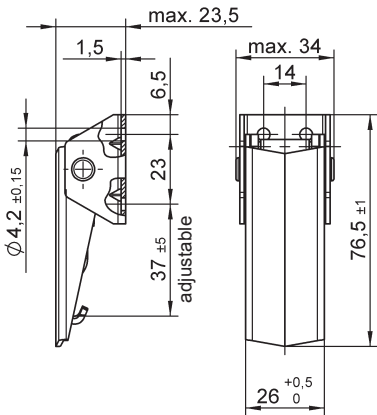
Style	Dimensions	Materials / Finish	Mounting Type ¹⁾	D	Part No.
Open base 		Steel / zinc-plated, CrVI-free, clear passivation ²⁾	N	5,1	V917L01-1-1AG
		Stainless steel ³⁾	N	5,1	V917L01-1-1BP
High base 		Steel / zinc-plated, CrVI-free, clear passivation ²⁾	N	4,2	V17L12-1-1AA

¹⁾ Mounting type: N = With hole for riveting or screw fixing



S = Without holes, for welding

²⁾ Max. tensile strength: 3.200 N with V917L11-1- *AG strike, working load 2.200 N.

2.200 N with V951L50-1- *AGV strike, working load 1.500 N.

³⁾ Max. tensile strength: 3.600 N with V951L50-1- *BP strike, working load 2.700 N.

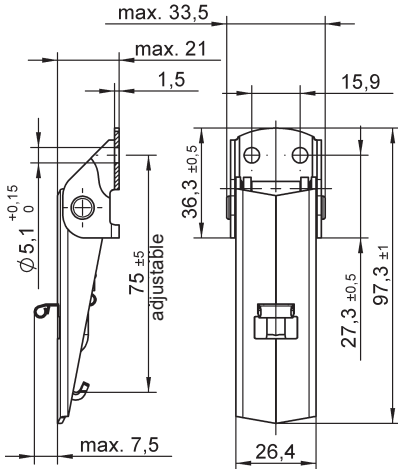
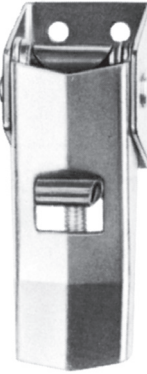
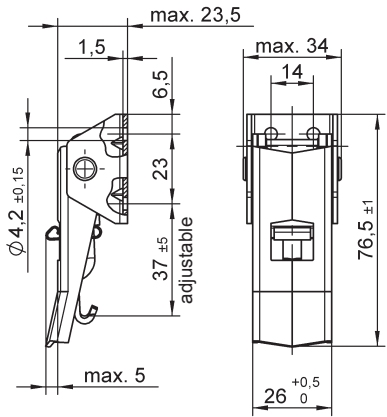

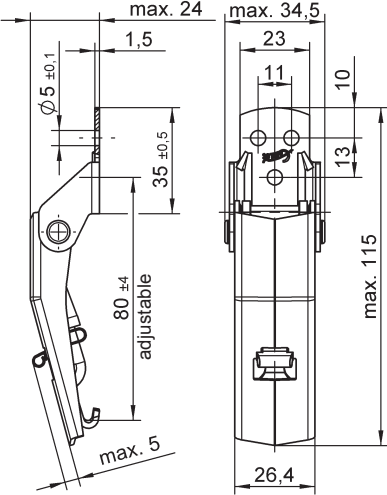
max. 2.300 N with V917L11-1-1BP strike, working load 1.550 N.

Style	Dimensions	Materials / Finish	Mounting Type ¹⁾	D	Part No.
Secondary lock, open base 		Steel / zinc-plated, CrVI-free, clear passivation ²⁾	N	5,1	V917L01-1X1AG
		Stainless steel ³⁾	N	5,1	V917L01-1X1BP
		Stainless steel ³⁾	S	-	V917L01-1X2BP
		Stainless steel V4A ³⁾	N	5,1	V917L01-1X1CP
		Stainless steel V4A ³⁾	S	-	V917L01-1X2CP
Secondary lock, high base 		Steel / zinc-plated, CrVI-free, clear passivation ²⁾	N	4,2	V17L12-2X1AA
Secondary lock, for curved surfaces (R min = 125 mm) 		Steel / zinc-plated, CrVI-free, clear passivation ²⁾	N	5,0	1449L02-1X1AG
		Stainless steel ³⁾	N	5,0	1449L02-1X1BP

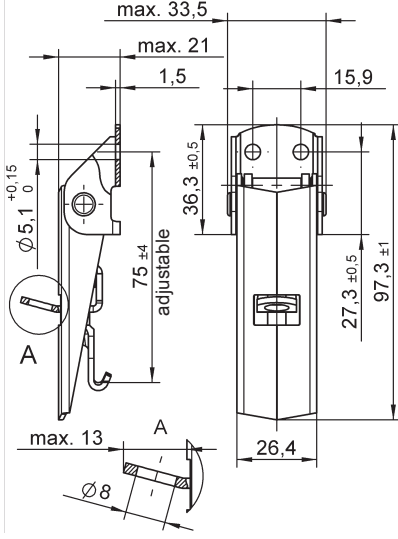
For footnotes refer to page G-1.

Style	Dimensions	Materials / Finish	Mounting Type ¹⁾	D	Part No.
<p>Open base, with hasp</p> 		Steel / zinc-plated, CrVI-free, clear passivation ²	N	5,1	V917L01-1Y1AG

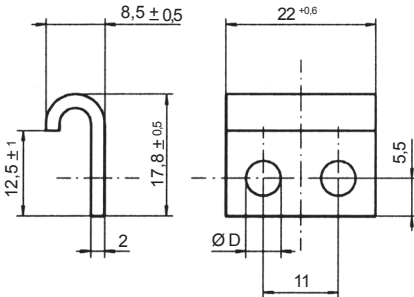
Strikes

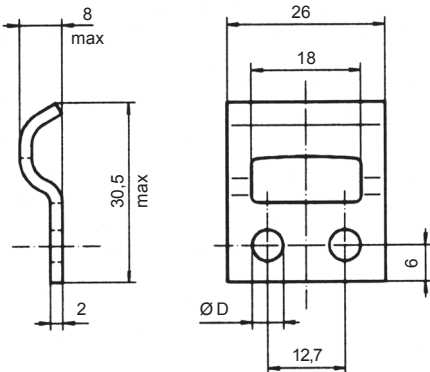
Style	Dimensions	Materials / Finish	Mounting Type ¹⁾	D	Part No.
<p>Open</p> 		Steel / zinc-plated, CrVI-free, clear passivation	N	5,1	V917L11-1-1AG
		Steel / zinc-plated, CrVI-free, clear passivation	N	4,2	V917L11-1-3AG
		Stainless steel	N	5,1	V917L11-1-1BP
<p>Closed</p> 		Steel / zinc-plated, CrVI-free, clear passivation	N	4,2	V951L50-1AGV
		Steel / zinc-plated, CrVI-free, clear passivation	N	5,1	V951L50-5AGV
		Stainless steel	N	4,2	V951L50-1BP
		Stainless steel	S	-	V951L50-3BP

For footnotes refer to page G-1.

Dimensions

Open-base tension latch / open strike

Type	L2	L2 min.	L2 max.
1-1	98	-10,5	+3,5
1Y1		-5,5	+3,5
1X1		-4,5	+2,5

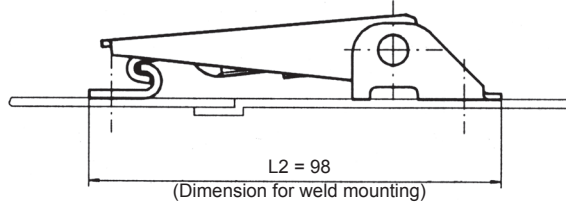

V917L01-*

V917L11-*

Type	L1	L1 min.	L1 max.
1-1	82	-9	+5
1Y1		-4	+5
1X1		-3	+4

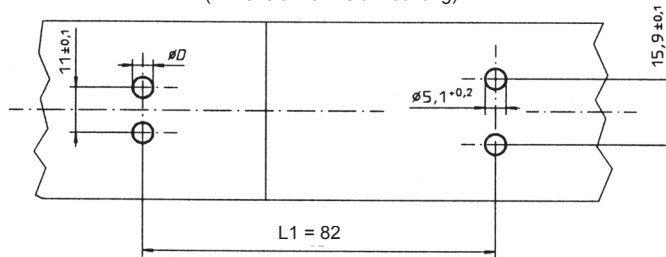

Select diameter D in accordance with the strike style.

Open-base tension latch / closed strike

Type	L2	L2 min.	L2 max.
1-1	105	-9	+5
1Y1		-5	+5
1X1		-4	+3

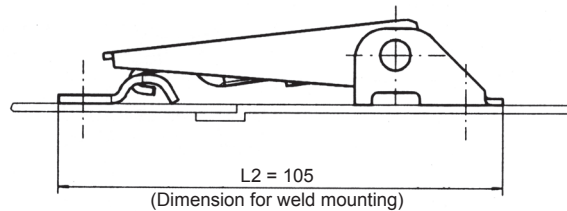

V917L01-*

V951L50-*

Type	L1	L1 min.	L1 max.
1-1	90	-9	+5
1Y1		-5	+5
1X1		-4	+3

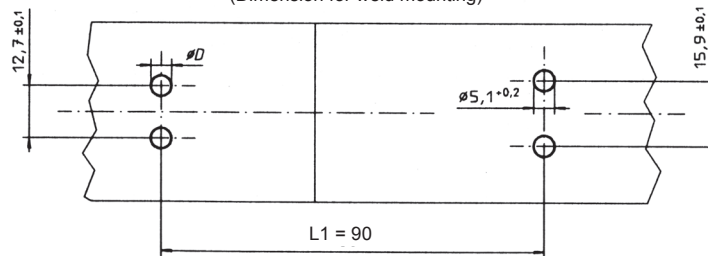

Select diameter D in accordance with the strike style.

Tension latch for curved surfaces

Type	L	L min.	L max.
1X1	101	-8	-

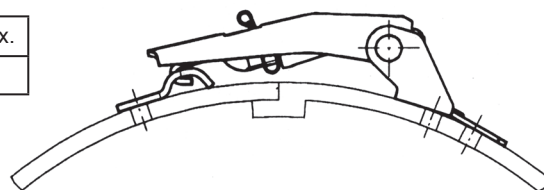

1449L02-*

V951L50-*

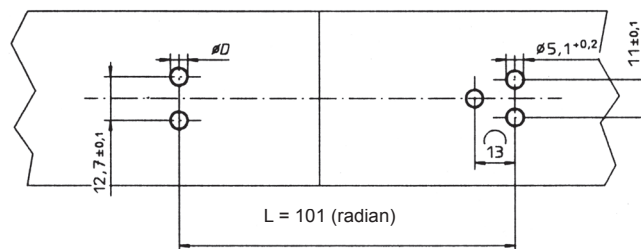

Select diameter D in accordance with the strike style.

Dimensions

High-base tension latch / open strike

Type	L	L min.	L max.
2X1	66	-4	+6

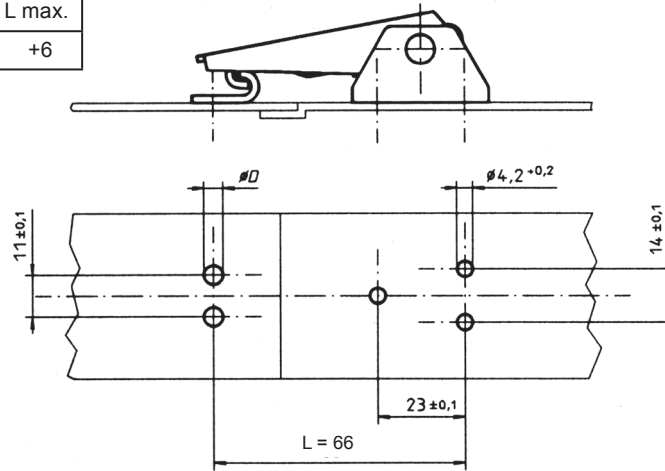

V17L12-*

V917L11-*

Select diameter D in accordance with the strike style.

Max. tensile strength 6.000 N, working load max. 4.200 N, see footnotes.
Adjustable drawhook
Available with secondary lock, hasp and lift spring

Style	Dimensions	Materials / Finish	Mounting Type ¹⁾	D	Part No.
		Steel / zinc-plated, CrVI-free, clear passivation ²⁾	N	5,1	V18L01-1-1AGV
		Stainless steel ³⁾	N	5,1	V18L01-1-1BP
		Stainless steel ³⁾	S	-	V18L01-1-2BP
With secondary lock 		Steel / zinc-plated, CrVI-free, clear passivation ²⁾	N	5,1	V18L01-1X1AGV
		Stainless steel ³⁾	N	5,1	V18L01-1X1BP
		Stainless steel ³⁾	S	-	V18L01-1X2BP

¹⁾ Mounting type: N = With hole for riveting or screw fixing
S = Without holes, for welding

²⁾ Max. tensile strength: 6.000 N with V18L13-1-1AP strike, working load 4.200 N.

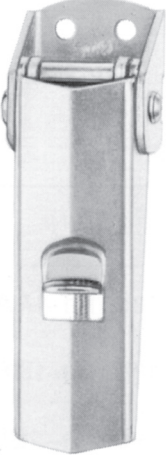
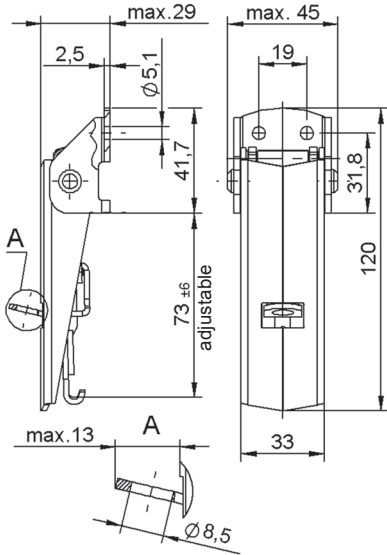

³⁾ Max. tensile strength: 4.600 N with V18L13-1-*BP or 1449L07-1BP strike, working load 3.100 N.

Style	Dimensions	Materials / Finish	Mounting Type ¹⁾	D	Part No.
<p>Hasp</p> 		Steel / zinc-plated, CrVI-free, clear passivation ²⁾	N	5,1	V18L01-1Y1AGV

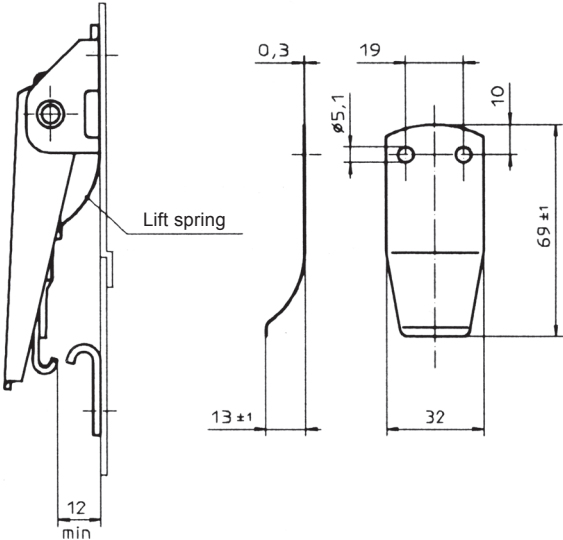
Accessories

Dimensions	Materials / Finish	Mounting Type ¹⁾	D	Part No.
<p>Lift spring</p> 	Stainless steel	N	5,1	V18L45-1BP

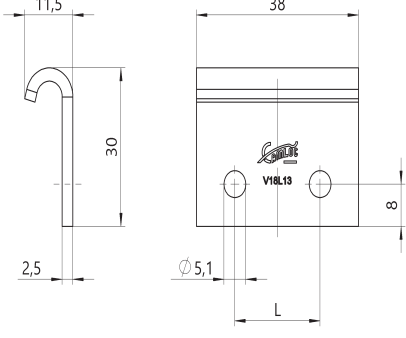
For footnotes refer to page H-1.

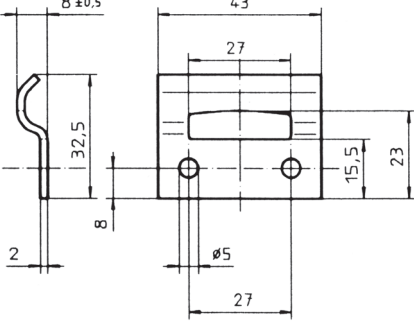
Style	Dimensions	Materials / Finish	L	Mounting Type ¹⁾	D	Part No.
Open 		Steel / zinc-plated, iridescent passivated and sealed	22	N	5,1	V18L13-1-1AGV
		Steel / zinc-plated, iridescent passivated and sealed	19	N	5,1	V18L13-1-3AGV
		Stainless steel	22	N	5,1	V18L13-1-1BP
		Stainless steel	-	S	-	V18L13-1-2BP
Closed 		Stainless steel		N	5,0	1449L07-1BP

For footnotes refer to page H-1.

Dimensions

Tension latch / open strike

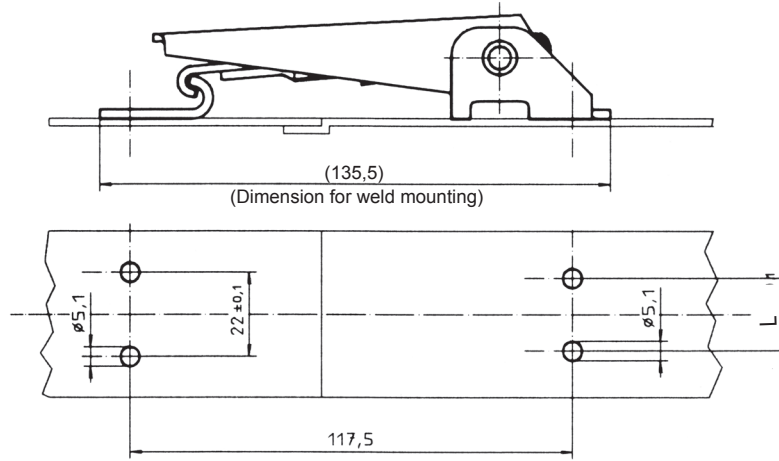

V18L01-*

V18L13-*

Tension latch / closed strike

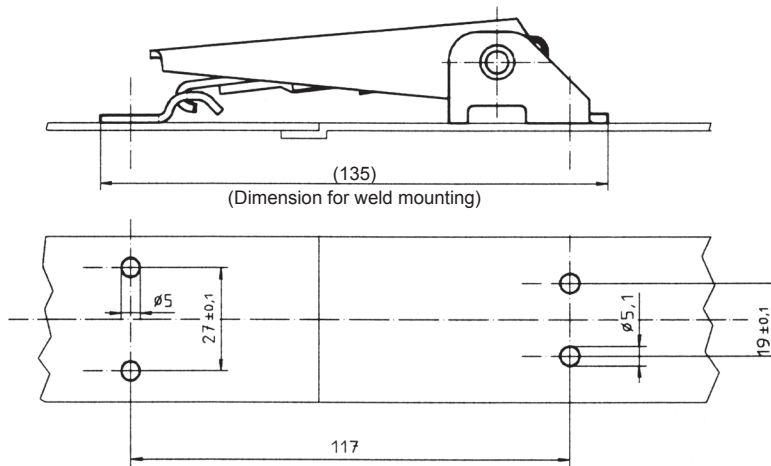

V18L01-*

1449L07-*

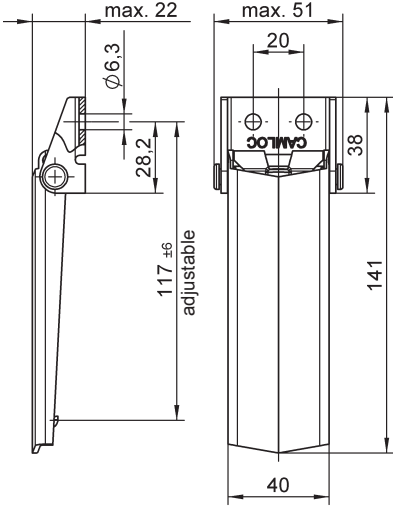

Max. tensile strength 4.500 N, working load 3.000 N.
Adjustable drawhook

Style	Dimensions	Materials / Finish	Mounting Type ¹⁾	D	Part No.
		Steel / zinc-plated, CrVI-free, clear passivation	N	6,3	V46L38-1-6AGV
		Steel / zinc-plated, CrVI-free, clear passivation	S	-	V46L38-1-1AGV

Strike

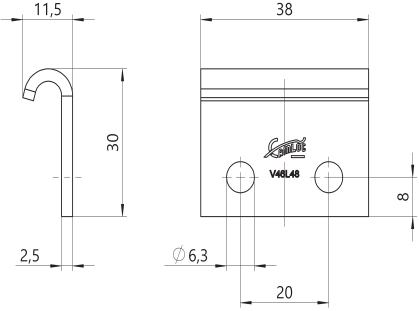
Style	Dimensions	Materials / Finish	Mounting Type ¹⁾	D	Part No.
		Steel / zinc-plated, iridescent passivated and sealed	N	6,3	V46L48-1-1AGV

¹⁾ Mounting type: N = With hole for riveting or screw fixing
S = Without holes, for welding

Dimensions

Tension latch open base / open strike

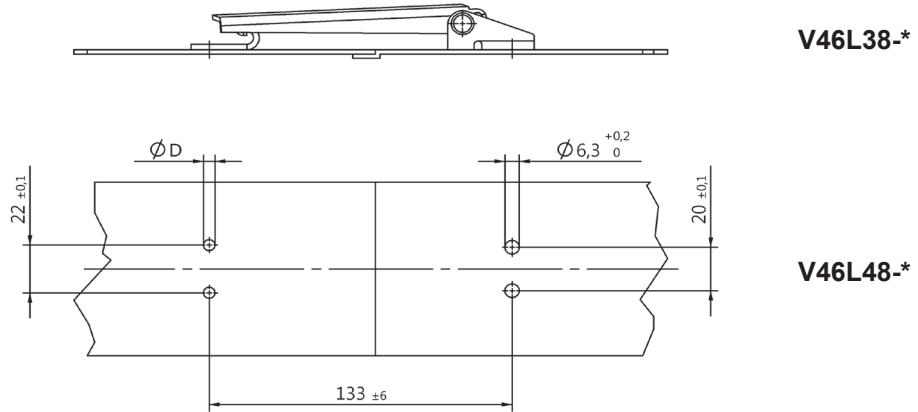

Part No.	Page	Part No.	Page	Part No.	Page
1429L02-1-1AG	E1	V917L01-1X2CP	G2	V951L50-5AGV	G3
1429L02-1-1BP	E1	V917L11-1-1AG	G3	V951L52-1AGV	F4
1429L02-1X1AG	E2	V917L11-1-3AG	G3	V951L52-1BP	F4
1429L02-1X1BP	E2	V917L11-1-1BP	G3	V951L61-4BP	F5
1429L02-2-1AG	E1	V934L01-1-1AGV	B1	V951L61-5BP	F5
1429L02-2-1BP	E1	V934L01-1X1AGV	B1	V951L7-1AD	F4
1429L02-2X1AG	E3	V934L02-1AGV	B1	V951L7-1AGV	F4
1429L02-2X1BP	E3	V934L01-1-1BP	B1	V951L7-1BP	F4
1429L02-3-1AG	E2	V934L01-1X1BP	B1	V951L7-2AZ	F4
1429L02-3-1BP	E2	V934L02-1BP	B1	V951L7-2BP	F4
1429L02-3X1AG	E3	V95H07-1-1BP	C1	V951L7-5AGV	F4
1429L02-3X1BP	E3	V95L07-1-1BC	C1	V951L7-5BP	F4
1429L8-1AG	E4	V95L15-1BD	C1	V96H01-1-1A0	D1
1429L8-1BP	E4	V951L01-1Y2AGV	F3	V96L01-1-1AG	D1
1429L9-1AG	E4	V951L01-1Y5AGV	F3	V96L01-1-1A0	D1
1429L9-1BP	E4	V951L02-1-1AD	F1	V96H01-1-2A0	D1
1449L02-1X1AG	G2	V951L02-1-1AGV	F1	V96L01-1-2AG	D1
1449L02-1X1BP	G2	V951L02-1-1BP	F1	V96L01-1-2A0	D1
1449L07-1BP	H3	V951L02-1-2AGV	F1		
V17L12-1-1AA	G1	V951L02-1-2BP	F1		
V17L12-2X1AA	G2	V951L02-1-5AGV	F1		
V18L01-1-1AGV	H1	V951L02-1-5BP	F1		
V18L01-1-1BP	H1	V951L03-1-1AD	F1		
V18L01-1-2BP	H1	V951L03-1-1AGV	F1		
V18L01-1X1AGV	H1	V951L03-1-1BP	F1		
V18L01-1X1BP	H1	V951L03-1-5AGV	F1		
V18L01-1X2BP	H1	V951L03-1-5BP	F1		
V18L01-1Y1AGV	H2	V951L03-1X1AD	F2		
V18L13-1-1AGV	H3	V951L03-1X1BP	F2		
V18L13-1-1BP	H3	V951L03-1X5AGV	F2		
V18L13-1-2BP	H3	V951L03-1X5BP	F2		
V18L13-1-3AGV	H3	V951L04-1X1AD	F2		
V18L45-1BP	H2	V951L04-1X1AGV	F2		
V46L38-1-6AGV	I1	V951L04-1X1BP	F2		
V46L38-1-1AGV	I1	V951L04-1X2BP	F2		
V46L48-1-1AGV	I1	V951L04-1X5AGV	F2		
V51L59-1ASNV	F5	V951L04-1X5BP	F2		
V917L01-1-1AG	G1	V951L05-1X1AGV	F3		
V917L01-1-1BP	G1	V951L05-1X1BP	F3		
V917L01-1X1AG	G2	V951L50-1AGV	F4,G3		
V917L01-1X1BP	G2	V951L50-1BP	F4,G3		
V917L01-1X2BP	G2	V951L50-2BP	F4		
V917L01-1X1CP	G2	V951L50-3BP	F4,G3		

